

Date _____
 AVFI Sales REP _____
 Customer Signature _____

Quote No. _____
 Customer No. _____
 AVFI No. _____

Office Use Only

To generate your order form, please refer to the information provided below to insert the alphabetic and/or numeric code in the respective category boxes. Please note that without this filled out Order Form, your purchase **cannot** be processed.

1 Product Model	2 Top Option	3 Finish	4 Chargeable Accessories (One Code Per Box)	5 Custom Cutouts
PD51				

1 Product Model

Optional Tops



Code **PD51**
(Standard Configuration)

5101TP-L (Left Overhang)



5101TP-R (Right Overhang)



5102TP (Double Overhang)



2 Choose Product Finish

Standard Finishes (Ships within 1-15 business days)



Code **CJT**
(Crossfire Java)



Code **ELT**
(Elegance)



Code **EBT**
(Ebony)

Optional Finishes (Ships within 20 business days)

FMT

HCT

RCT

CLT

ART

BRT

CWT

BAT

SGT

Comments (Please use this section to provide additional information)

Notes

CAD Drawings/Symbols
 CAD drawings are available by request at sales@vegroup.net

Custom Cutouts
 Estimated lead time within 20 business days from receipt of P.O. and signed drawings.

Customizations
 Modifications to design such as shape and/or size variations have to be quoted on a per case basis and are applicable for quantities of 10+ only.

2 Choose Top Option (Extra Charges Apply)

Code **C7** 5101TP-L (58" Left Overhang Worktop)
 Code **C8** 5101TP-R (58" Right Overhang Worktop)
 Code **C9** 5102TP (58" Double Overhang Worktop)

3 Chargeable Accessories (Check all that apply)

Code **00** No Accessories _____ Qty _____
 Code **A4** SH-FL-51 Folding Side Shelf Kit..... Qty _____
 Code **B1** 9031-1 1U Utility Metal Shelf Qty _____
 Code **B2** 9031-2 2U Utility Metal Shelf Qty _____
 Code **B3** 9031-3 3U Utility Metal Shelf Qty _____
 Code **B4** 9041 Sliding Metal Shelf (Rear Rack Rail required) Qty _____
 Code **B5** 9052-2 2U Sliding Metal Drawer Qty _____
 Code **B6** 9052-3 3U Sliding Metal Drawer Qty _____
 * Code **D1** MIC-18 MX418 S/C Microphone Qty _____
 * Code **D2** LIGHT-18 Gooseneck Light Qty _____
 * Code **D3** FM3 Timer/Clock Qty _____
 Code **E1** PB 6 Outlet Power Bar Qty _____
 * Code **E3** CUB3 Round Cable Well Qty _____
 * Code **E4** SF-PB3 3 Outlet Power Bar Qty _____
 * Code **E5** CUB5 Black Round Cable Well Qty _____
 * Code **E6** CUB5 Silver Round Cable Well Qty _____
 * Code **E7** PC-PATCH Power-Data Module Qty _____
 * Code **E8** CUB8 Table Top Cable Well Qty _____
 * Code **EA** CUB4S Silver Power Panel Qty _____
 * Code **EB** CUB4B Black Power Panel Qty _____
 § * Code **EF** CHGQIB Wireless Charging Station Black Qty _____
 Code **F9** 5104TP Bridge Top Qty _____
 Code **FA** 5104DE Desk End (ADA Compliant) Qty _____
 Code **J1** 9107 Lacing Bar Qty _____
 Code **J5** DIR9200-12 12U Rack Module Qty _____
 Code **K1** C900S Single Monitor Arm Qty _____
 § Code **K3** PLM1022 Monitor Mount Qty _____
 Code **K4** MM1232 Monitor Mount Qty _____
 Code **M5** MCB1925 Monitor/Camera Bracket Qty _____
 Code **Q1** LEV4A4X 4x Levelers for Non-Mobile Applications Qty _____
 * Code **EJ** CUB22 Power Panel Qty _____
 * Code **EK** CUBM3 3-Module Power & Data Panel Qty _____
 * Code **EL** CUBM4 4-Module Power & Data Panel Qty _____
 Code **N7** CHLD245 Metal Swivel Cup Holder Qty _____
 § Code **K2** C900D Dual Monitor Arm Qty _____

* Cutout Required (Extra Charges will apply)
 § Only on Flat Cutout

Custom Cutout Option on Page 2

Please indicate custom cutout location on the drawing(s) below

5 Custom Cutout Option (Extra charges will apply)

PD51 - Standard Configuration

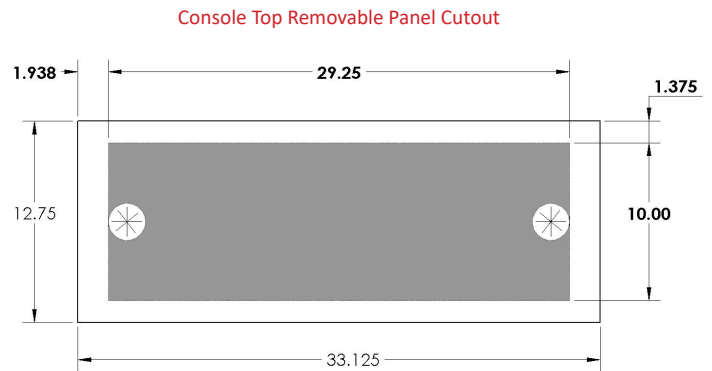
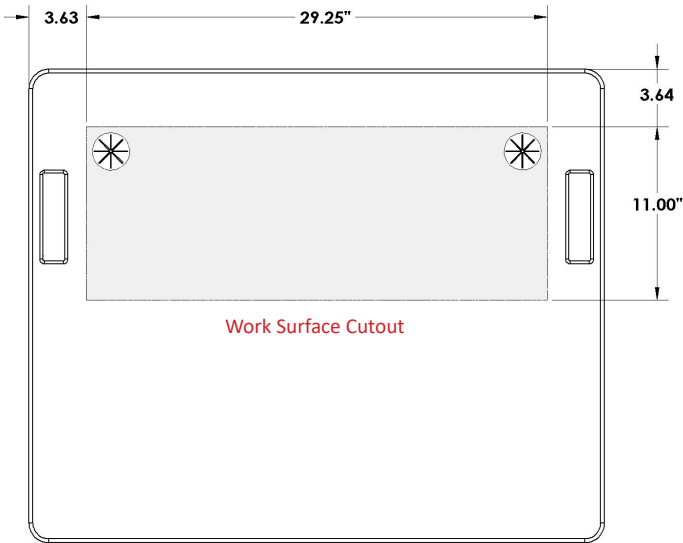

PD51 - Optional Worktops

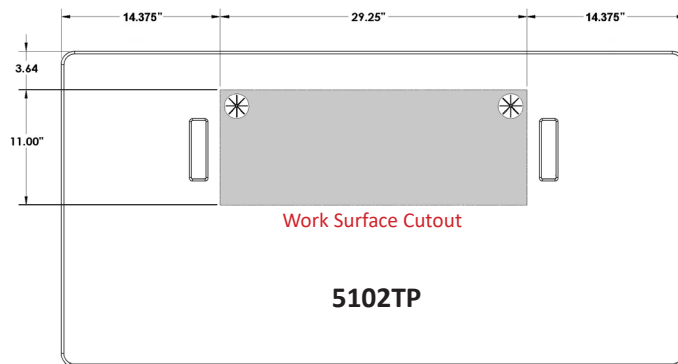
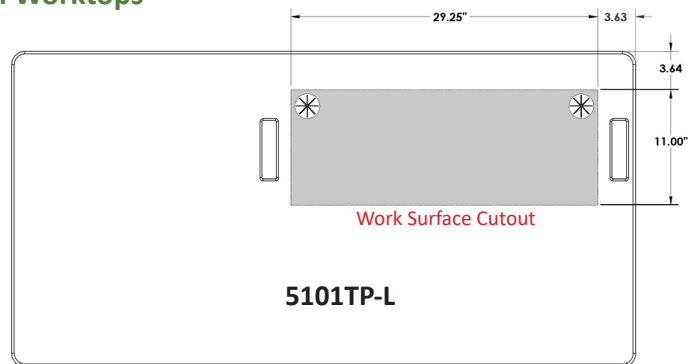
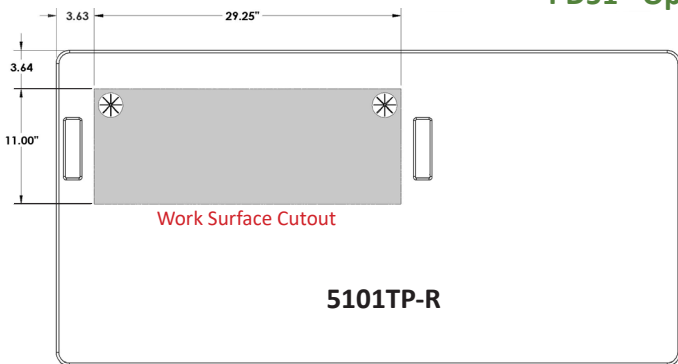

Code **CO** No Custom Cutout
Code **CC** Custom Cutout (Specify on Cutout Area Above)

- Cutout Area - Work Surface (29.25"W X 11"D)
- Cutout Area - Removable Console Top (29.25"W X 10"D)
- Cutout Area - Optional Worktop (29.25"W X 11"D)